



**ProGlass**  
Professional Glass

*YELLOW KIT F1*

*BLACK KIT R1*

*WHITE KIT F3*

*RED KIT C1*

**MANUAL DE MONTAJE**  
MAMPARAS DE BAÑO

	PRESENTACIÓN	3
	MEDIDAS P/VIDRIOS 8MM	4
	HERRAMIENTAS	5
■	KIT BOX FRONTAL F1	6
□	KIT BOX FRONTAL F3	16
■	KIT BOX ESQUINERO C1	26
■	KIT REBATIBLE R1	37

PARA CRISTAL TEMPLADO 8mm

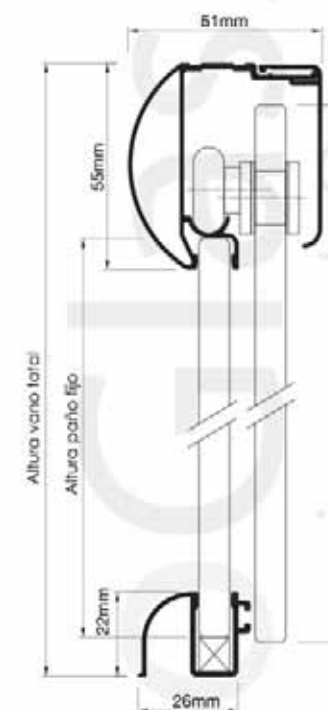

## DETALLE DESCUENTOS MAMPARA DE BAÑO PROGLASS

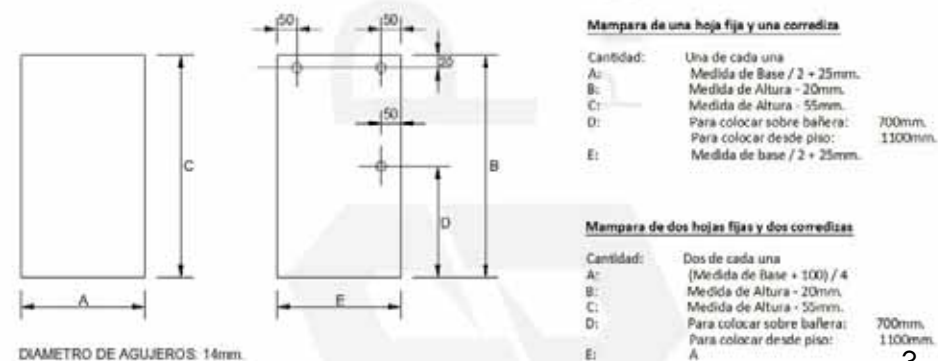

## VIDRIOS DE 8MM

### DESCUENTO PARA RUEDAS



### DESCUENTO PARA TIRADOR

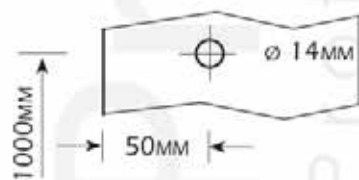

### PERFIL GUIA

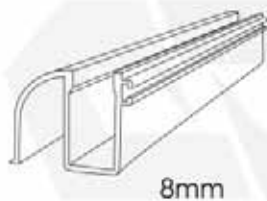

## HERRAMIENTAS

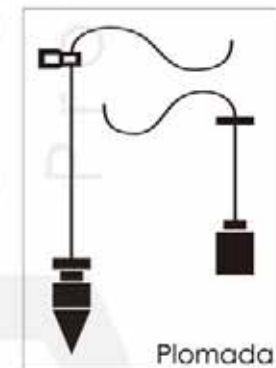
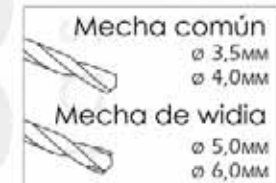

# F1 KIT BOX FRONTAL F1



6

# F1 LOCALIZACIÓN

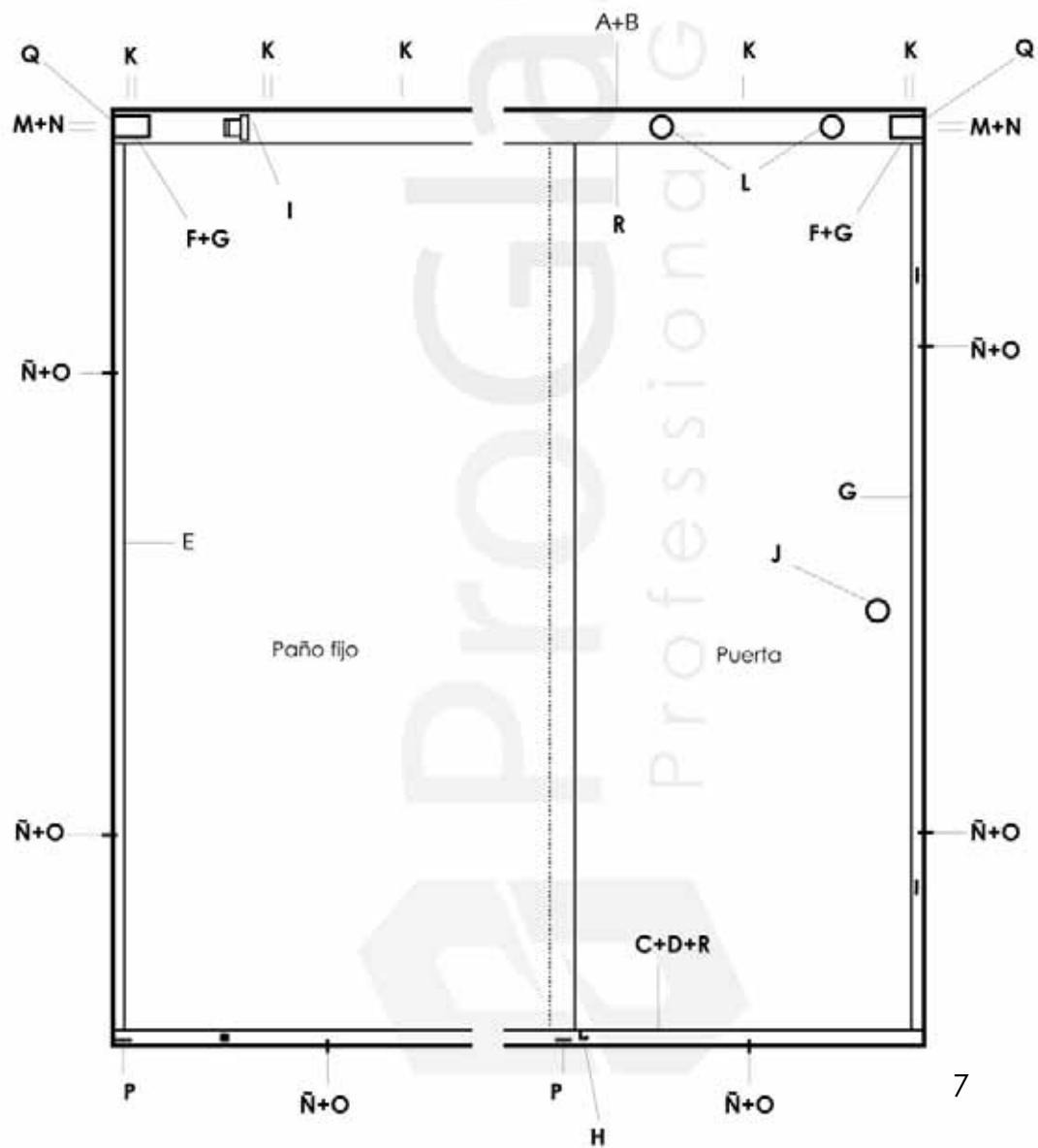

7

# F1 CONTENIDO

Item	Cant.	Descripción	Foto
A	01	PERFIL CABEZAL	
B	01	PERFIL TAPA	
C	01	PERFIL GUIA	
D	01	PERFIL TAPA DESAGUE	
E	01	PERFIL "U" 12x12	
F	02	SOPORTE FIJACIÓN	
G	02	CUÑA TRABA DEL SOPORTE	
H	01	GUIA INFERIOR	
I	01	FRENO SUPERIOR	
J	01	TIRADOR	

Item	Cant.	Descripción	Foto
K	08	REMACHE POP	
L	02	RODAMIENTOS	
M	04	TORNILLO CABEZA PLANA Ø 3,9x32MM	
N	04	TARUGO 6MM	
Ñ	06	TORNILLO CABEZA FRESADA Ø 3,5x22MM	
O	06	TARUGO 5MM	
P	02	CUÑA DE REGULACIÓN	
Q	02	TERMINACIÓN CABEZAL	
R	01	FELPA	

PD: LOS ELEMENTOS DE FIJACIÓN (K, L, M, N) SON PARA USO EN OBRA

## 01 MONTAR PERFIL GUIA (C)



## 02 MARCAR LOS AGUJEROS DEL SOPORTE (F) USANDO EL PERFIL "U" 12x12mm (E)



## 03 FIJAR PERFIL "U" 12x12mm (E)

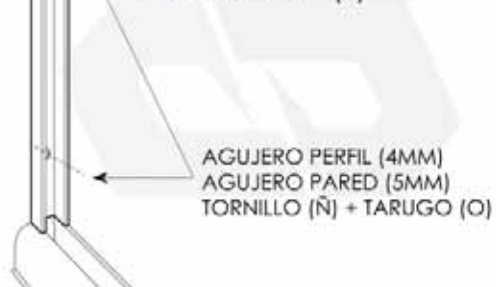

## 04 FIJAR LOS SOPORTES (F)

AGUJERO PARED (6MM)  
TORNILLO (M) + TARUGO (N)

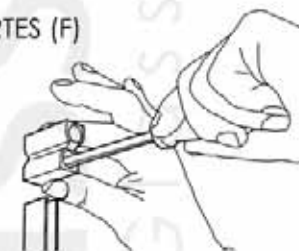

## 05 CORTAR EL PERFIL CABEZAL (A) 4mm MENOR QUE EL ANCHO DEL VANO Y COLOCAR LAS TERMINACIONES (Q) EN LOS EXTREMOS



## 06

COLOCAR EL CONJUNTO DEL PERFIL CABEZAL (A) Y LAS TERMINACIONES (Q) SOBRE LOS SOPORTES DE FIJACIÓN (F)



AGUJERO P/ REMACHE (K) (3.5MM)

## 07 TRABAR EL CONJUNTO CON LA CUÑA TRABA DEL SOPORTE (G) Y REMACHAR



08

TRABAR EL PAÑO FIJO CON LA CUÑA DE REGULACIÓN (P)



09

VERIFICAR LA NIVELACIÓN

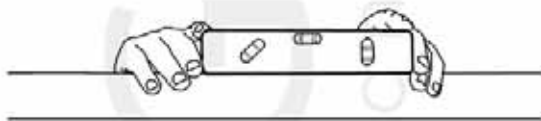

10

COLOCAR LA GUIA INFERIOR (H) EN EL PERFIL GUIA (C)



11

COLOCAR LOS RODAMIENTOS (L) Y TIRADOR (J) EN LA PUERTA

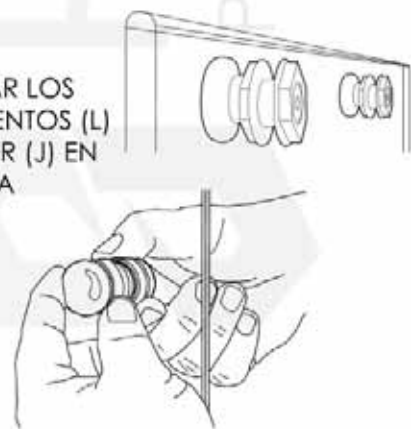

12

COLOCAR LA PUERTA LISTA EN EL PERFIL CABEZAL (A) Y EN LA GUIA INFERIOR (H)



13

REGULAR LA PUERTA

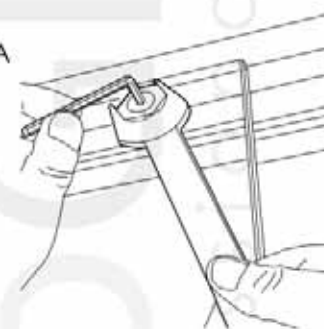

14

INSTALAR EL PERFIL "U" 12x12



- 15** DETERMINAR LA POSICIÓN DE PARADA DE LA PUERTA Y FIJAR EL FRENO SUPERIOR (i)

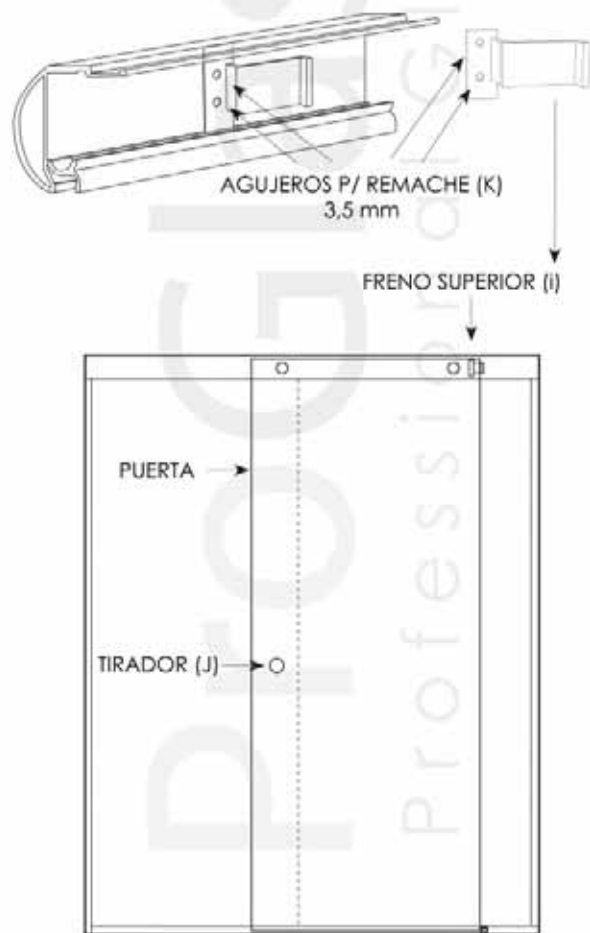

- 16** DETERMINAR LAS MEDIDAS, CORTAR Y ENCAJAR LA TAPA DESAGUE (D), LOS CANALES DEL PERFIL CABEZAL (A) Y GUIA (C). ENCAJAR LA FELPA (R) EN EL PERFIL GUIA (C)



- 17** DETERMINAR LAS MEDIDAS, CORTAR Y ENCAJAR EL PERFIL TAPA (B) EN PERFIL CABEZAL (A) Y REMACHAR

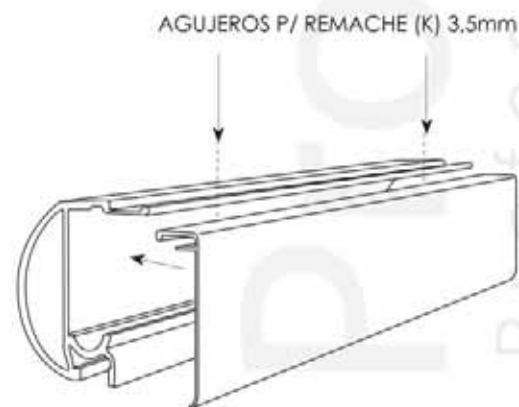

- 18** SELLAR TODO EL PERIMETRO INTERNO ENTRE PERFIL Y AZULEJO. UTILIZAR SILICONA ANTIHONGOS





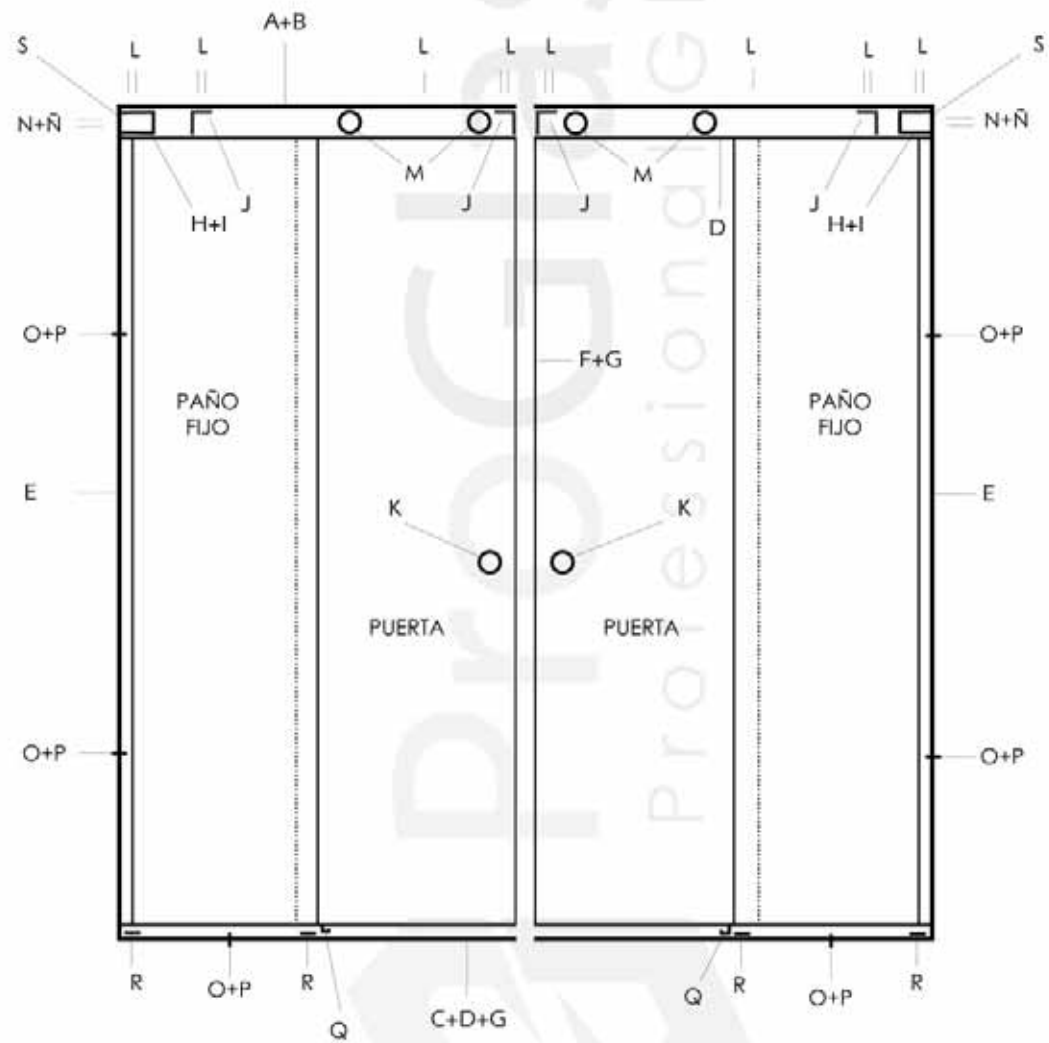

### F3 CONTENIDO

Item	Cant.	Descripción	Foto
A	01	PERFIL CABEZAL	
B	01	PERFIL TAPA	
C	01	PERFIL GUIA	
D	01	PERFIL TAPA DESAGUE	
E	02	PERFIL "U" 12X12	
F	01	PERFIL "H" DE ENCUENTRO FRONTAL	
G	01	FELPA	
H	02	SOPORTE FIJACIÓN	
I	02	CUÑA TRABA DEL SOPORTE	
J	04	FRENO SUPERIOR	
K	02	TIRADOR	
L	14	REMACHE POP	

Item	Cant.	Descripción	Foto
M	04	RODAMIENTOS	
N	04	TORNILLO CABEZA PLANA Ø 3,9x32MM	
Ñ	04	TARUGO 6 MM	
O	06	TORNILLO CABEZA FRESADA Ø 3,5x22MM	
P	06	TARUGO 5 MM	
Q	02	GUIA INFERIOR	
R	04	CUÑA DE REGULACIÓN	
S	02	TERMINACIÓN CABEZAL	
PD: LOS ELEMENTOS DE FIJACIÓN (N, Ñ, O, P) SON PARA USO EN OBRA			

## 01 MONTAR PERFIL GUIA (C)

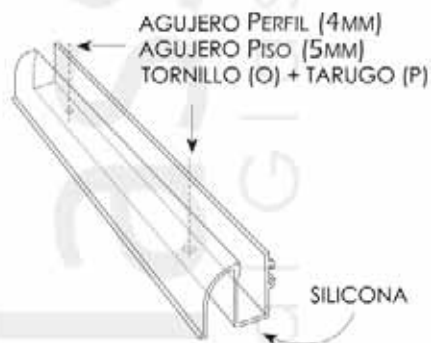

## 02 MARCAR LOS AGUJEROS DEL SOPORTE (H) USANDO EL PERFIL "U" 12x12mm (E)



SILICONA

## 03 FIJAR PERFIL "U" 12x12mm (E)

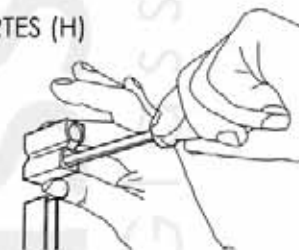

## 04 FIJAR LOS SOPORTES (H)

AGUJERO PARED (6MM)  
TORNILLO (N) + TARUGO (Ñ)

## 05 CORTAR EL PERFIL CABEZAL (A) 4mm MENOR QUE EL ANCHO DEL VANO Y COLOCAR LAS TERMINACIONES (S) EN LOS EXTREMOS



## 06

COLOCAR EL CONJUNTO DEL PERFIL CABEZAL (A) Y LAS TERMINACIONES (S) SOBRE LOS SOPORTES DE FIJACIÓN (H)

AGUJERO P/ REMACHE (L) (3.5MM)



## 07 TRABAR EL CONJUNTO CON LA CUÑA TRABA DEL SOPORTE (I) Y REMACHAR

08

TRABAR EL PAÑO FIJO CON LA CUÑA DE REGULACIÓN (R)



09

VERIFICAR LA NIVELACIÓN

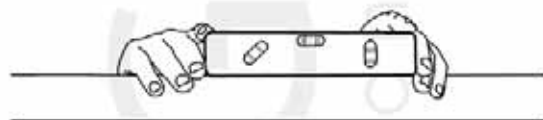

10

COLOCAR LA GUIA INFERIOR (Q) EN EL PERFIL GUIA (C)



11

COLOCAR LOS RODAMIENTOS (M) Y TIRADOR (K) EN LAS PUERTAS

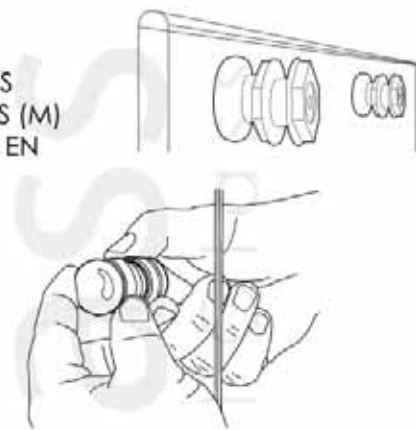

12

COLOCAR LA PUERTA LISTA EN E PERFIL CABEZAL (A) Y EN LA GUIA INFERIOR (Q)



13

REGULAR LA PUERTA

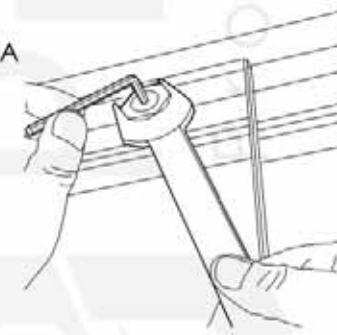

- 14** DETERMINAR LA POSICIÓN DE PARADA DE LAS PUERTAS Y FIJAR LOS FRENOS (J)

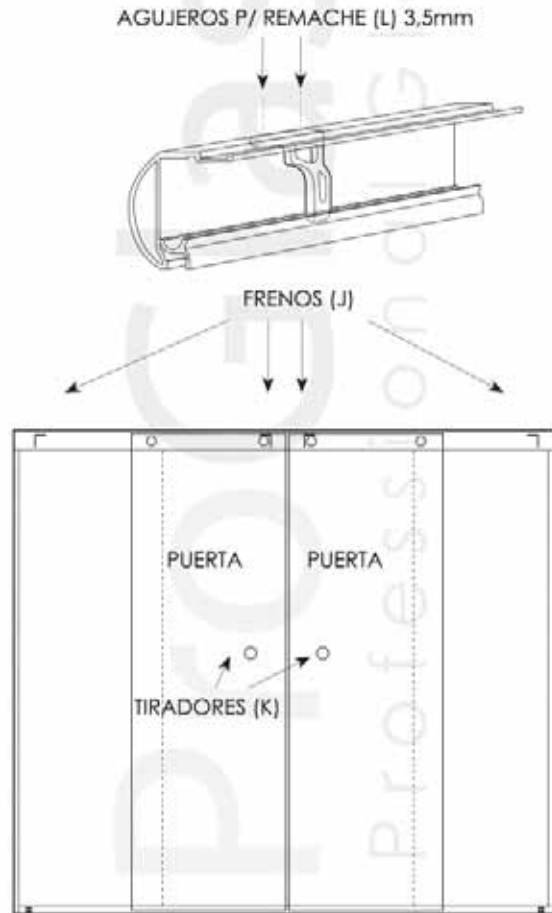

- 15** DETERMINAR LAS MEDIDAS, CORTAR Y ENCAJAR LA TAPA DESAGUE (D), LOS CANALES DEL PERFIL CABEZAL (A) Y GUIA (C). ENCAJAR LA FELPA (G) EN EL PERFIL GUIA (C)



- 16** DETERMINAR LAS MEDIDAS, CORTAR Y ENCAJAR EL PERFIL TAPA (B) EN PERFIL CABEZAL (A) Y REMACHAR

- 17** COLOCAR LA FELPA (G) EN EL PERFIL "H" DE ENCUENTRO FRONTAL (F). CORTAR LA MEDIDA CORRECTA Y ENCAJAR EN LA PUERTA



- 18** SELLAR TODO EL PERIMETRO INTERNO ENTRE PERFIL Y AZULEJO. UTILIZAR SILICONA ANTIHONGOS

## 2 FIJOS Y 2 PUERTAS

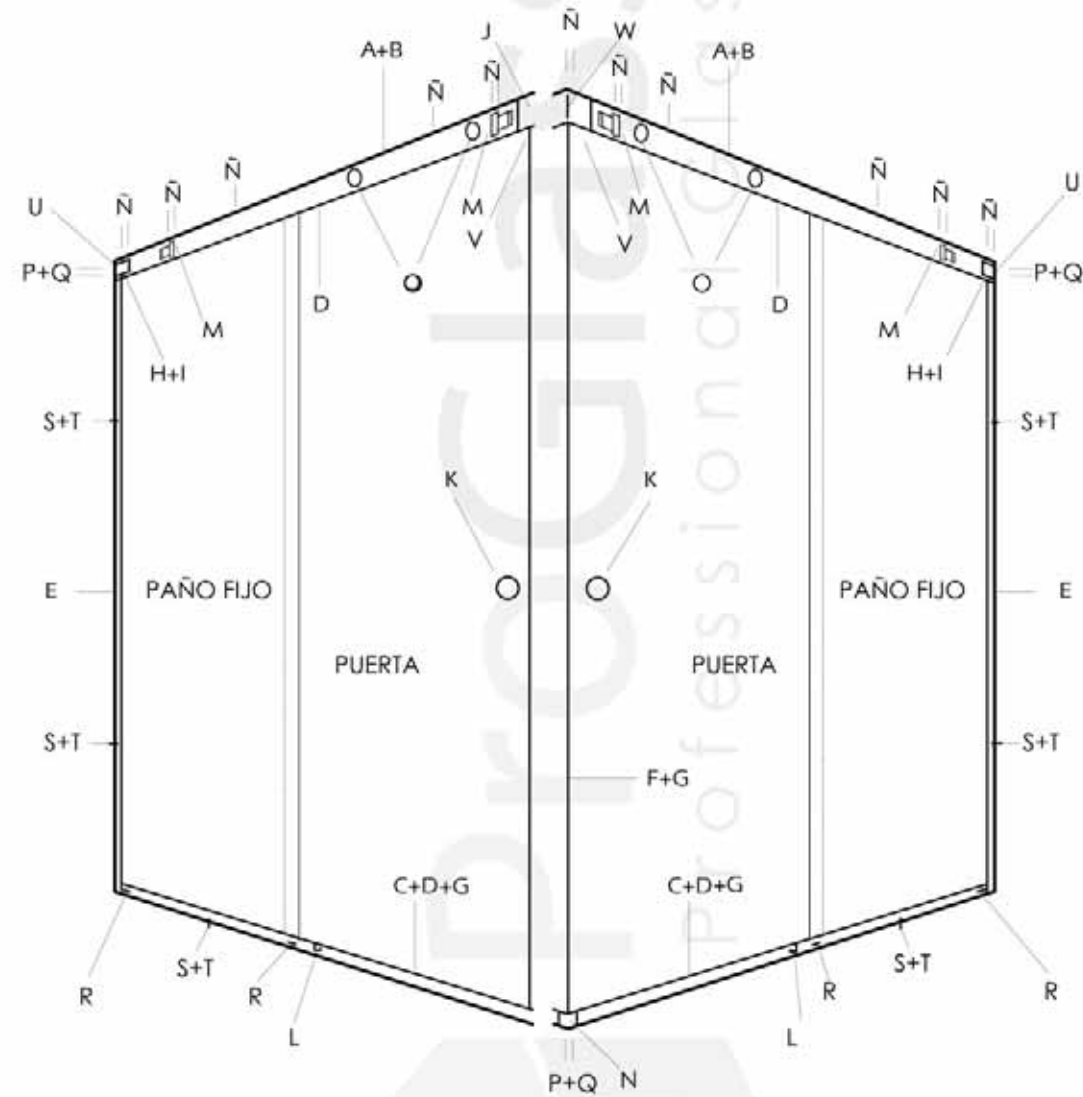

# C1 CONTENIDO

Item	Cant.	Descripción	Foto
A	02	PERFIL CABEZAL	
B	02	PERFIL TAPA	
C	02	PERFIL GUIA	
D	02	PERFIL TAPA DESAGUE	
E	02	PERFIL "U" 12x12	
F	01	PERFIL DE ENCUENTRO DE ESQUINERO	
G	01	FELPA	
H	02	SOPORTE DE FIJACIÓN	
I	02	CUÑA TRABA DEL SOPORTE	
J	01	JUNTA DE ESQUINERO SUPERIOR	
K	02	TIRADOR	
L	02	GUIA INFERIOR	

Item	Cant.	Descripción	Foto
M	04	FRENO SUPERIOR	
N	01	JUNTA ESQUINERO INFERIOR	
Ñ	18	REMACHE POP	
O	04	RODAMIENTOS	
P	06	TORNILLO CABEZA PLANA Ø 3,9x32MM	
Q	06	TARUGO 6MM	
R	04	CUÑA DE REGULACIÓN	
S	06	TORNILLO CABEZA FRESADA Ø 3,5x22MM	
T	06	TARUGO 5MM	
U	02	TERMINACIÓN CABEZAL	
V	02	TORNILLO CABEZA PLANA Ø 3,5x13MM	
W	01	JUNTA ESQUINERO SUPERIOR IZQUIERDO	

PD: LOS ELEMENTOS DE FIJACIÓN (P, Q, S, T)  
SON PARA USO EN OBRA

- 01** POSICIONAR Y FIJAR LOS PERFIL GUIA (C) Y LA JUNTA ESQUINERO INFERIOR (N) DEBIDAMENTE ENCAJADOS

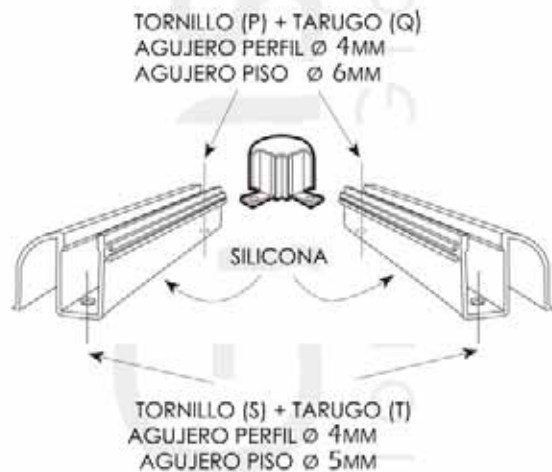

- 02** MARCAR LOS AGUJEROS DEL SOPORTE DE FIJACION (H) USANDO EL PERFIL "U" 12x12 mm (E)



- 03** FIJAR LOS PERFILES "U" 12x12 mm (E)

AGUJERO PERFIL (4mm)  
AGUJERO PARED (5mm)  
TORNILLO (S) + TARUGO (T)

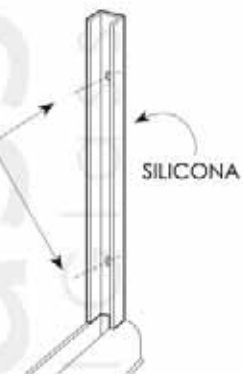

- 04** FIJAR LOS SOPORTES DE FIJACION (H)



- 05** CORTAR LOS PERFILES CABEZAL (A) 4mm MENOR Y ENCAJAR LA JUNTA DE ESQUINERO SUPERIOR (J) Y LAS TERMINACIONES DE CABEZAL (U) EN LOS EXTREMOS

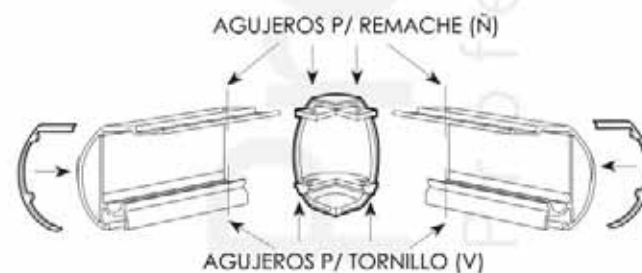

- 06** ENCAJAR EN CONJUNTO LOS SOPORTES DE FIJACION (H), TRABAR CON LA CUÑA TRABA DEL SOPORTE (I) Y REMACHAR

AGUJEROS P/ REMACHE (Ñ) (3.5mm)

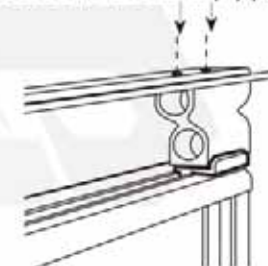



**07** TRABAR LOS PAÑOS FIJOS CON LAS CUÑAS DE REGULACIÓN (R)



**08** VERIFICAR LA NIVELACIÓN DEL CONJUNTO

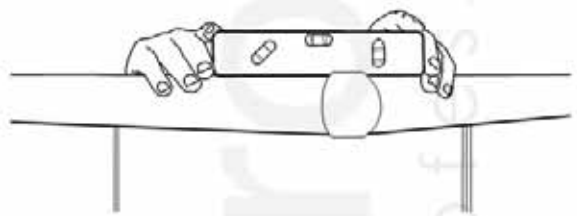

**09** COLOCAR LAS GUIAS INFERIORES (L) EN LOS PERFILES GUIA (C)

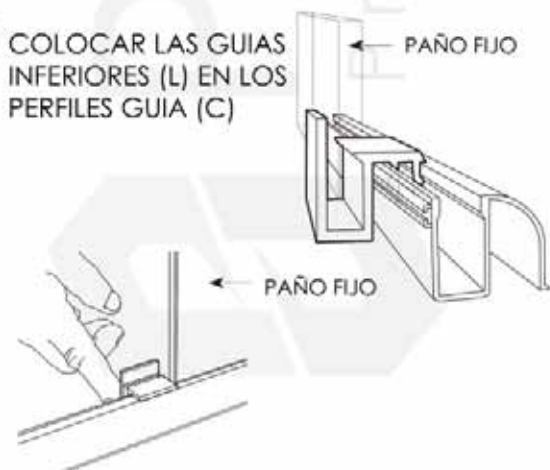

**10** MONTAR LOS RODAMIENTOS (O) Y LOS TIRADORES (K) EN LAS PUERTAS

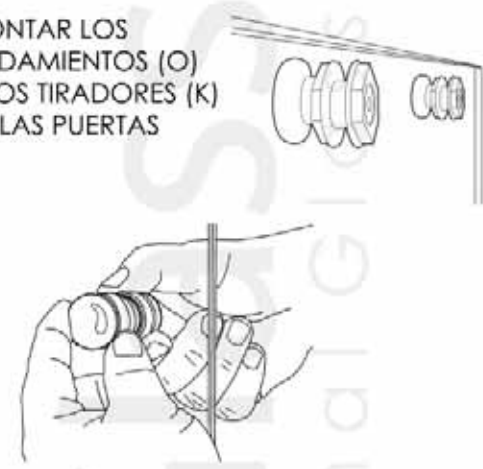

**11** COLOCAR LAS PUERTAS MONTADAS EN LOS PERFILES CABEZALES Y LAS GUIAS INFERIORES

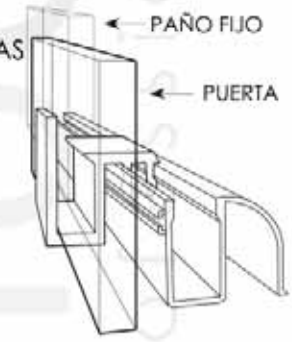

**12** REGULAR LAS PUERTAS

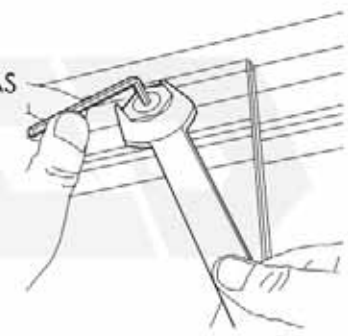

- 13** DETERMINAR LA POSICIÓN DE PARADA DE LAS PUERTAS Y FIJAR LOS FRENOS (M)

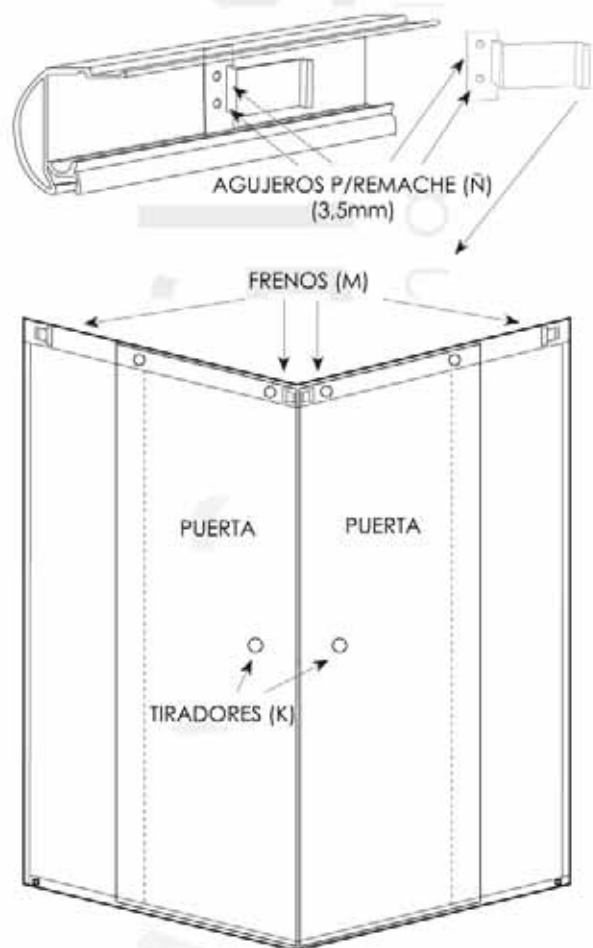

- 14** DETERMINAR LAS MEDIDAS, CORTAR Y ENCAJAR LOS FERFILES TAPA DESAGUE (D) EN LOS CANALES DE LOS PERFILES CABEZAL (A) Y GUIA (C) ENCAJAR LAS FELPAS EN EL PERFIL GUIA (C)

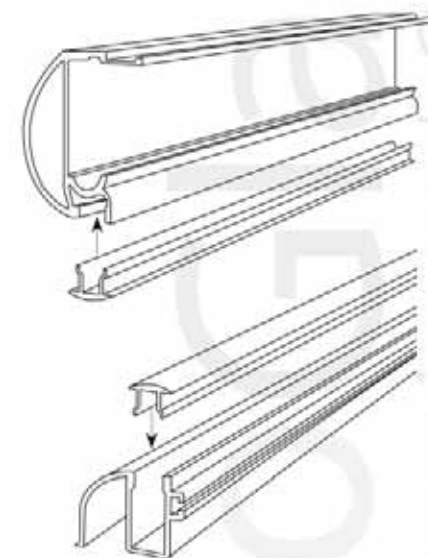

- 15** DETERMINAR LAS MEDIDAS, CORTAR Y ENCAJAR LOS FERFILES TAPA (B) EN LOS PERFILES CABEZAL (A)

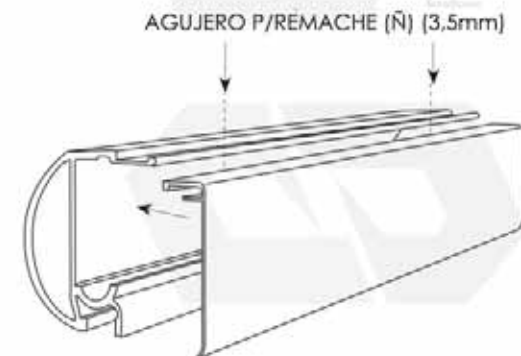

- 16** ENCAJAR LA JUNTA ESQUINERA SUPERIOR INTERNA (Z) EN LA UNIÓN DE LOS PERFILES TAPA (B) Y REMACHARLOS EN LOS PERFILES CABEZAL (A)

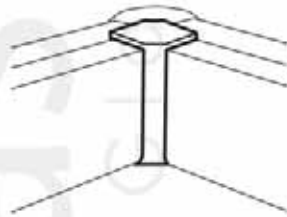

- 17** COLOCAR LA FELPA (G) EN EL PERFIL "H" DE ENCUENTRO DE ESQUINERO (F), CORTAR LA MEDIDA CORRECTA Y ENCAJAR EN LA PUERTA

- 18** SELLAR TODO EL PERIMETRO INTERNO ENTRE PERFIL Y AZULEJO. UTILIZAR SILICONA ANTIHONGOS



## R1 DESCUENTOS

PARA CRISTAL TEMPLADO 8mm

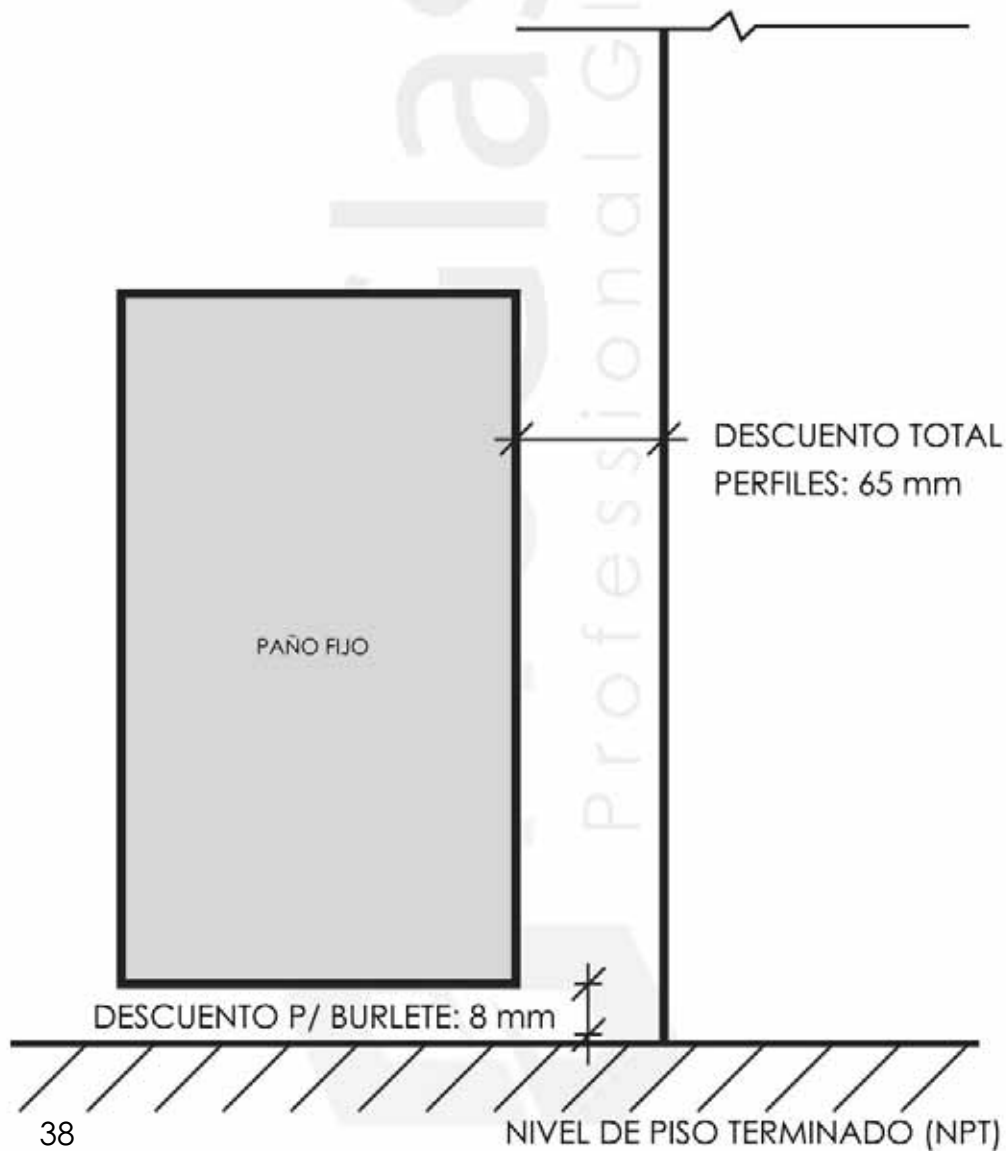

## R1 MONTAJE

01 AJUSTAR PERFILES A MEDIDA

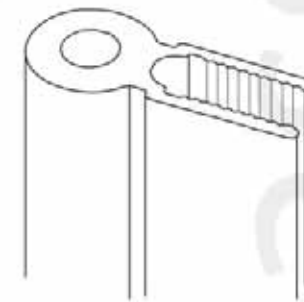

PERFIL VIDRIO:  
MEDIDA DEL PAÑO



PERFIL PARED:  
MEDIDA DEL PAÑO + 4 mm

02 DESATORNILLAR CHAPA PIVOT SUPERIOR Y SACAR LA FELPA

03 FIJAR PERFIL PARED

AGUJEROS PARED (6 mm)  
AGUJEROS PERFIL PARED (6 mm)

AGUJEROS PERFIL VIDRIO (10 mm)

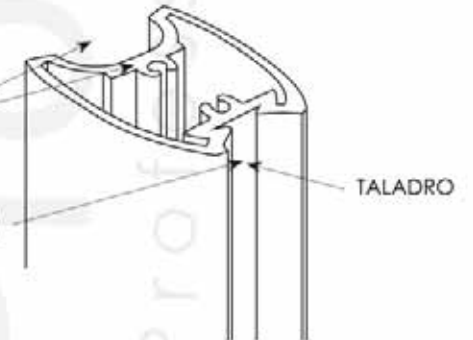

04 SELLAR PERFIL VIDRIO A CRISTAL 8 mm TENIENDO EN CUENTA LA FALSA ESCUADRA. COLOCAR BURLETE BARREDOR INFERIOR

05 CALZAR EL PAÑO EN EL PIVOT INFERIOR Y AJUSTAR PIVOT SUPERIOR



# ProGlass

Professional Glass

[info@proglass.com.ar](mailto:info@proglass.com.ar) | [www.proglass.com.ar](http://www.proglass.com.ar)  
Tel.: (54 11) 4926-0788 | José Marmol 856, Cdad. Aut. Bs. As. (C1236ABJ)